



C900 Operating Instructions



ISO 9001:2000 CERTIFIED

*www.cardinalcomponents.com · info@cardinalcomponents.com
W128 N8600 Old Orchard Rd., Menomonee Falls, WI 53051
Visa, Mastercard, Discover & AmerExp Accepted · Fax: 262.252.5033*

**CALL TODAY
800.236.3200**

Table of Contents

SECTION	Page No.
I. General	
Rivnut-Plusnut Header	2
Air Supply Requirements	2
Hydraulic System	2
II. Operation and Adjustments	
Header and Pump Operation	2
Pull-Up Stud/Anvil Replacement	3
Measuring Rivnut Pull-Up	3
Determining Amount of Pull-Up Required	4
Adjusting for Correct Pull-Up	4
III. Maintenance	
Service Instructions SP8115 Header ...	5
Service Instructions AP9901-02-10 Air Pump	6
IV. Trouble Shooting	
Trouble Shooting Chart	9

Section I- General

Rivnut/Plusnut Header

The C-900 Model "B" Tool is specifically designed to upset Rivnut and Plusnut brand metal fasteners with thread sizes 5mm to 12mm, 10-32 through 1/2-13. It will give long service with minimum care when kept clean and in proper adjustments according to the instructions that follow. An easily made external adjustment modifies the header stroke length to accommodate a change in material thickness.

Recommended Air Inlet Pressure

It is recommended that a good air regulator be used to avoid not exceeding maximum recommended working pressure of 80 psi. Recommended operating pressures are 75 to 80 psi. Air must be free from dirt and moisture. To promote long trouble-free pump operation, be sure the air line is equipped with an air filter regulator.

Hydraulic System

To fill oil reservoir hold pump on end with oil reservoir up and remove fill plug. Fill to top with #10 light weight hydraulic oil. Replace the fill plug and hand tighten only.

Section II- Operation And Adjustments

Header and Pump Operation

Connect a 9 CFM (minimum) air supply to the 1/4" NPTF pump air inlet swivel connector. Use a small amount of pipe dope on the pipe threads to insure sealing. Tighten pipe connections securely but not excessively. Remember the recommended air pressure is 75-80 psi. To activate pump, depress treadle. A practice cycle is sufficient to master the operation of tool. Operate the tool in three steps:

1. Thread fastener on pull-up stud until fastener head touches anvil. Insert fastener in pre-drilled or punched hole.
2. Depress foot pedal, activating air pump, which will retract pull-up stud, consequently upsetting the fastener. When installation is completed, release foot pedal, releasing hydraulic load.
3. Rotate torque knob (11) counterclockwise. This will reverse pull-up stud from installed fastener.

ISO 9001:2000 CERTIFIED

CALL TODAY
800.236.3200

C900 Tool

Pull-Up Stud and Anvil Adjustment or Replacement (Reference Figure 1.)

1. Complete pull-up stud assembly, including torque knob (11), shaft (10), spring (13), and washer (12), can be removed from the header by loosening set screw (8) and unthreading adjustable stop (9) from the header.

WARNING

Disconnect air supply before removal of pull-up stud assembly.

Pull-up stud or stud holder may be separated from the shaft (10) by loosening set screw (15). For two-piece stud and stud holder, loosen set screw in stud holder to remove and replace stud. See Table 2 for selection of pull-up studs, stud holders and anvils.

2. The anvil may be removed and replaced by loosening set screw (8). Anvil should be adjusted so that the fastener, when threaded onto stud with its head against face of anvil, fully engages threads of fastener. (For blind end Rivnuts, pull-up stud should be approximately one-half turn from bottoming in end of fastener).

Measuring Rivnut Pull-Up

(Reference Figures 1 and 2)

1. After stud is installed and anvil adjustment is completed, measure and record overall length of the fastener. (Figure 2)

2. Thread fastener on pull-up stud.
3. Loosen set screw (8) and turn adjusting nut (9) in until a definite stop is felt; then back adjusting nut (9) out one complete turn. This adjustment will provide a slight upset of the fastener (approximately .083").
4. Connect air line to air pump. Activate foot pedal, upsetting fastener and reverse foot pedal releasing hydraulic load.
5. Remove fastener and measure overall length of pulled up fastener (Fig. 2).
6. The measured difference between the fastener before pull-up and after pull-up is the amount tool is adjusted.

WARNING

Excessive pull-up may break pull-up stud, strip the fastener threads, or both. Inadequate pull-up may result in loose installations.

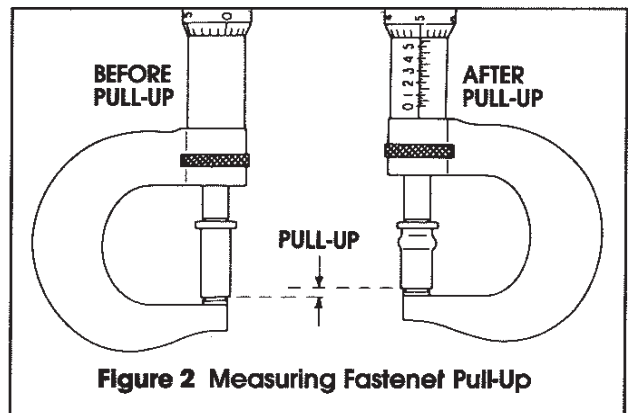

Figure 2 Measuring Fastener Pull-Up

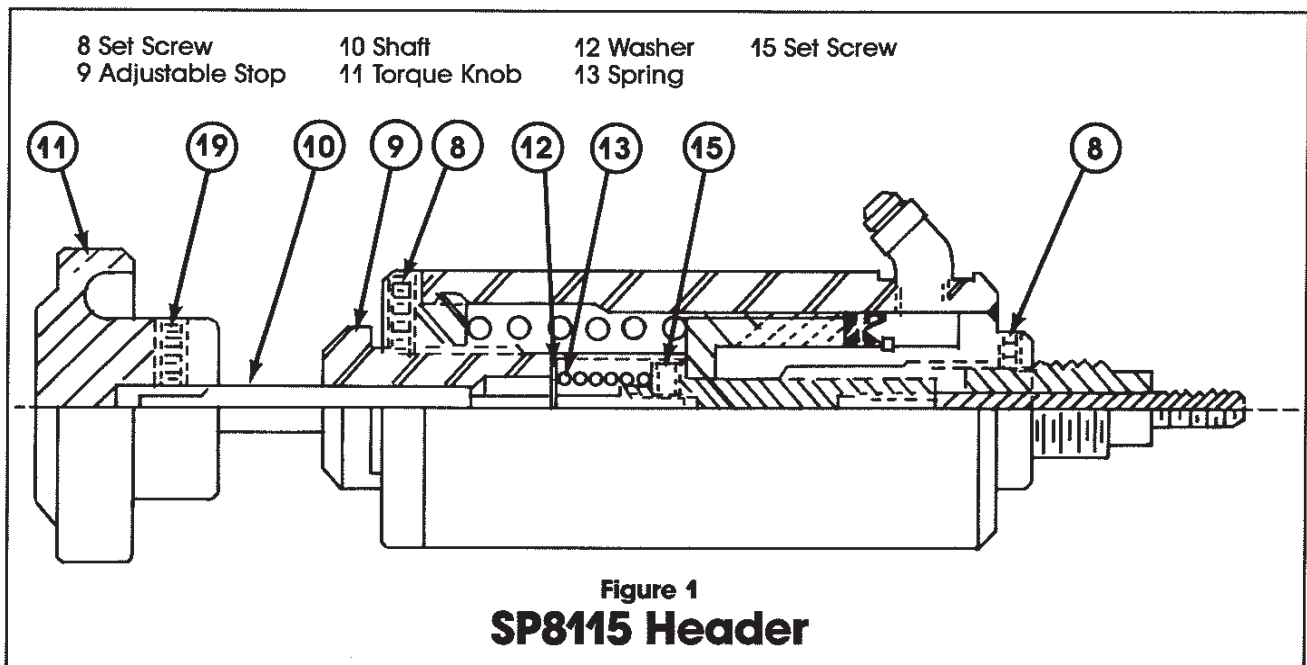

Figure 1
SP8115 Header

ISO 9001:2000 CERTIFIED

CALL TODAY
800.236.3200

C900 Tool

Determining the Amount of Pull-Up Required

- Each fastener will accommodate thicknesses of materials between the minimum and maximum grip limits (explained in detail in Rivnut/Plusnut data book).
- Refer to Table 1 to determine correct pull-up factor needed as explained below.
 - Measure with micrometer, overall thicknesses of materials in which fastener will be installed (for dimpled or countersunk holes, measure from top surface of metal to underside of dimpled hole). Always include air gaps, paint, or any burrs which cannot be removed.
 - Determine recommended maximum grip of Rivnut or Plusnut (stamped on box label, or refer to Rivnut/Plusnut data book).
 - Subtract material thickness (a) from recommended maximum grip (b).
 - Add difference to applicable pull-up factor from Table 1. This sum is a close approximation of the pull-up required to attain a proper bulge.
 - Compare pull-up recorded under number 6 (Page 3) with amount required as determined. Difference indicates amount of pull-up increase or decrease necessary.
 - Slight differences ($\pm .005$ inch) may require no further adjustment. Install several fasteners in sample material for checking.

Examples:

S10-80 Rivnut to be installed in .060 inch material:

Material thickness060
Maximum grip of Rivnut080
Difference (.080-.060)020
Sum (.020 + .080 pull-up factor)100
Pull-up required100

S25P280 Plusnut to be installed in .125 inch material:

Material thickness125
Maximum grip of Plusnut280
Difference (.280-.125)155
Sum (.155 + .215 pull-up factor)370

Adjusting for Correct Pull-Up

- Rotate the Adjustable Stop (9), Figure 1, clockwise into the body of the header to decrease pull-up. Rotating the Adjustable Stop counterclockwise increases the pull-up.
Note: One complete revolution of the Adjustable Stop changes the pull-up approximately .083.
- Tighten set screw (8) after final adjustments are made.
- Install Rivnut in sample plate using same thickness as the application.

TABLE 1

Fastener Thread Size	PULL-UP FACTOR - INCHES			
	Round Rivnut	Heavy Duty Hex Rivnut	Standard Hex Rivnut	Plusnut
No. 10	.080	—	.060	.195
1/4	.095	.080	.075	.215
5/16	.120	.120	.085	.270
3/8	.155	.120	.110	.310
1/2	.185	—	.120	—
	Round Rivnut	Hex Shank Rivnut		Plusnut
M5	.095	.065		.200
M6	.115	.070		.215
M7	.115	—		—
M8	.125	.120		.270
M10	.150	.120		.310
M12	.180	—		—

TABLE 2 - PARTS REQUIRED TO CONVERT TOOL TO OTHER THREAD SIZES

Unified Thread System

Thread Size	Pull-Up Stud	Pull-Up Stud Holder	Anvil	Plusnut Pull-Up Stud
10-24	RP-70-1024	HP-50-10	HP3-10	RP-70-1024
10-32	RP-70-1032	HP-50-10	HP3-10	RP-70-1032
12-24	P-146-1224	HP-50-25	HP3-12	—
1/4-20	P-146-2520	HP-50-25	HP3-25	RP-99-2520
1/4-28	P-146-2528	HP-50-25	HP3-25	RP-99-2528
5/16-18	HP-2-3118	Not Required	*P-83630	HP-2-3118
5/16-24	HP-2-3124	Not Required	*P-83630	HP-2-3124
3/8-16	HP-2-3716	Not Required	*P-83631	HP-2-3716
3/8-24	HP-2-3724	Not Required	*P-83631	HP-2-3724
1/2-13	HP-2-5013	Not Required	P-132-50	—
1/2-20	HP-2-5020	Not Required	P-132-50	—

Metric Thread System

M5X0.8	P-194-M5	HP-50-25	HP-58-M5	RP-143-M5
M6X1.0	P-194-M6	HP-50-25	HP-58-M6	RP-143-M6
M7X1.0	HP-44-M7	Not Required	HP-58-M7	—
M8X1.25	HP-44-M8	Not Required	P-196-M8	HP-44-M8
M10X1.50	HP-44-M10	Not Required	P-196-M10	HP-44-M10
M12X1.75	HP-44-M12	Not Required	P-196-M12	—

*Standard Hex Rivnuts Require: P-182-31 for 5/16 Thread Size. P-182-37 for 3/8 Thread Size.

ISO 9001:2000 CERTIFIED

CALL TODAY
800.236.3200

C900 Tool

Section III— Maintenance

Maintenance is simple because the C-900 Header requires only the usual care that should accompany the handling of any high quality precision tool.

Should any irregularities of performance develop in the course of getting the tool properly adjusted or after a long period of service, refer to Service Instructions and Trouble Shooting Chart or return the complete tool to BFGoodrich for service.

In disassembly and reassembly, guard against distortion, burring, or scarring of parts. Before reassembly, be sure parts are clean and in serviceable condition.

Service Instructions— SP8115 Header

Should maintenance be required because of oil leakage in header, the following procedures should be followed with extreme care:

Disassembly and Assembly of Header

1. Remove pull-up stud assembly as described in Section II, (Page 3).
2. Remove cap (7) with care, since spring (6) is compressed.
3. Remove spring (6), piston (5), bearing (4), back-up (3), and U-cup (2) by depressing treadle (55) of pump and applying slight hydraulic pressure to header, forcing U-cup, piston, etc. from header.
4. Reassemble parts by hand in reverse order.

Note: Caution should be used in replacing U-cup (2).

ITEM NO.	DESCRIPTION	PART NO.	QTY. REQ'D.	ITEM NO.	DESCRIPTION	PART NO.	QTY. REQ'D.
1	Cylinder weldment	B8628.900	1	11	Torque knob	A8005.147	1
2	U-cup	A8031.041	1	12	Washer	B1092.108	1
3	Back-up	A8018.562	1	13	Spring	A8133.110	1
4	Bearing	A8073.155	1	14	Stud holder/stud	See table II	1
5	Piston	A8003.052	1	15	Set screw	A66.087	4
6	Spring	A8134.110	1	16	45° elbow fitting	A8007.094	1
7	Cap	A8023.570	1	17	Ref. ring	A8040.049	1
8	Set screw	A8019.027	2	18	Decal	Not serviced	1
9	Adjustable stop	A8077.006	1	19	Set screw	C909.087	1
10	Shaft	A8013.288	1	20	Anvil	See table II	1

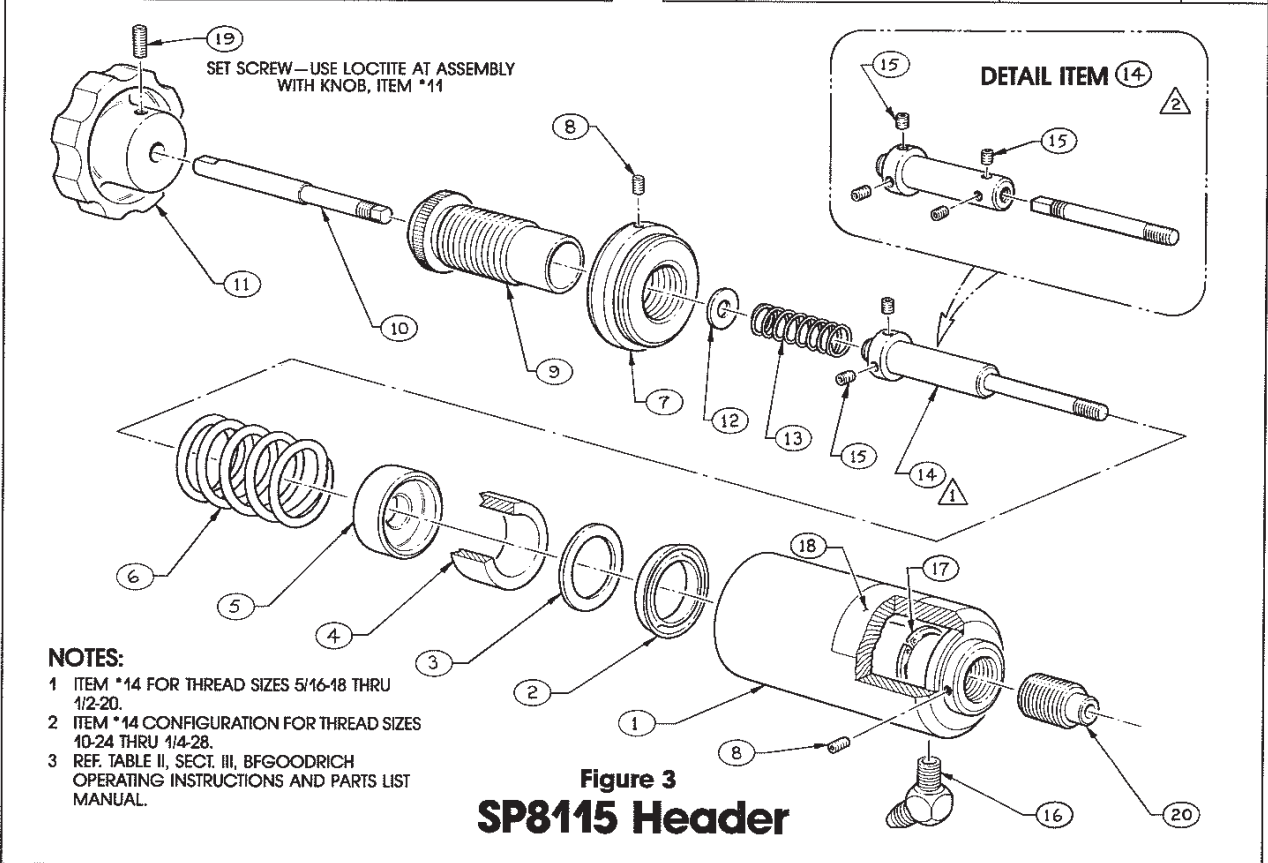

ISO 9001:2000 CERTIFIED

CALL TODAY
800.236.3200

Service Instructions— AP9901-02-10 Air Pump

Should maintenance be required for this unit, the following procedures should be used following closely the exploded views provided.

Disassembly and Assembly of Pump

(Reference Figure 4)

1. Air Motor Filter

If air motor does not perform as normal, check for a clogged air filter. If air filter is damaged, the following procedures should be followed to replace air filter:

- Shut off air pressure to pump and disconnect air hose.
- Grasp swivel coupler (42) with one hand and pull retaining ring (43) with pliers.
- Pull the swivel coupler (42) out.
- Carefully remove air filter (38). Turn counterclockwise.
- Clean air filter (38) with air hose or replace with a new one.
- Grease air filter threads before reassembly.
- Reinsert air filter (38) but do not over-torque.
- Put a thin film of grease on the "O" ring (41) of swivel coupler (42).
- Carefully reassemble swivel coupler (42) and retaining ring (43).
- Double check to insure swivel coupler (42) is securely attached before turning air pressure back on.

2. Air Motor

Drain hydraulic oil from tool. Disconnect air supply.

- Remove cap screws (63) holding on base plate (62). Loosen "V" retaining coupling (61) by unscrewing feed screw part of assembly (61). Caution should be taken to prevent spring (19) from separating motor from pump too rapidly.
- Holding motor upright (motor above pump), lift off and remove spring (19), washer (20), and plunger (21). Reinsert plunger (21) into cylinder (15) to prevent oil leakage or contamination.
- Withdraw air piston (22) from motor cylinder (27) by pulling on internal ribs. Inspect and replace piston (22), or "U" cup (23) if needed. Lightly coat "U" cup (23) with oil before reassembling.
- Remove washer seal (25 and 26) by unscrewing pan head screw (24). Inspect for damage. Replace if needed.
- Remove four cap screws (40) and remove cover (34) from air motor cylinder (27). Remove piston (30). Inspect and replace "O" rings if needed. Coat "O" rings with a light grease before reassembling in reverse order.

Remove air filter per instruction. Remove cover (34) from cylinder (27). Inspect and replace cover seal (33) if needed. Poppet plunger (32) fits through cover (34) and then grommet (37) fits over small ball end section of poppet plunger (32).

If replacement of "O" ring (35) and bushing (36) is necessary, refer to detail "B" on assembly drawing (Figure 4).

3. Air Throttle Valve

- Air throttle valve—remove 2 spring pins (47), then carefully pry assembly up. Caution should be taken to avoid prying on "O" rings or seals. Damaged or nicked parts should be replaced.
- After thoroughly cleaning all parts and replacement of worn or damaged parts, reassemble by referring to figure 4 for correct part sequences.

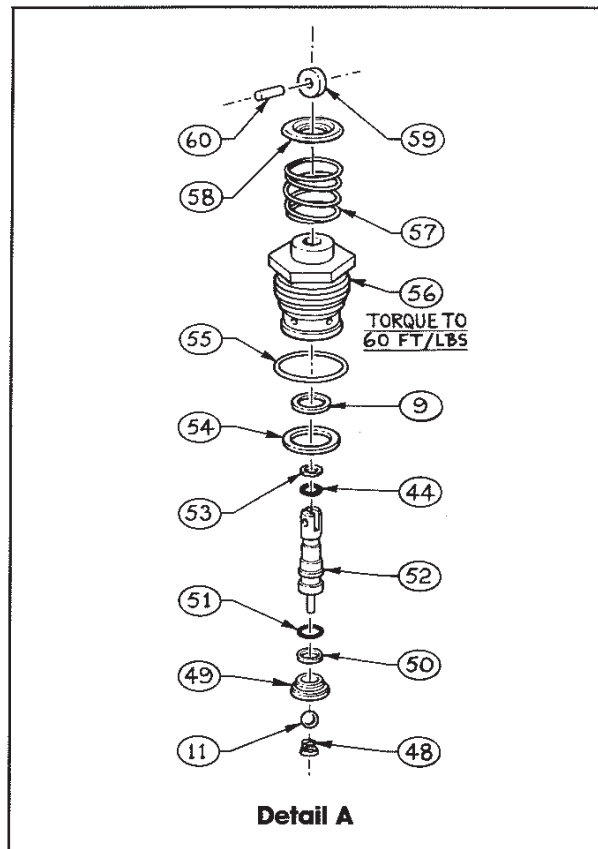

4. Hydraulic Release Plunger and Sub-Assembly (Detail A)

- Release plunger and roller sub-assembly. Removal of this unit can only be accomplished after removal of treadle (64). See figure 4 for details. After removing treadle, unscrew complete sub-assembly, then carefully depress spring (57) by pressing down with fingers on spring washer (58). This will take the tension off roller (59) and dowel pin (60), which then will allow dowel pin (60) to be pushed out of roller (59) and plunger (52). Carefully release spring

ISO 9001:2000 CERTIFIED

CALL TODAY
800.236.3200

C900 Tool

ITEM NO.	DESCRIPTION	PART NO.	QTY. REQ'D.	ITEM NO.	DESCRIPTION	PART NO.	QTY. REQ'D.
1	Reservoir can*	CF709.025	1	48	Spring	CH813.110	1
2	Reservoir*	CB921.025	1	49	Ball seat	CM66.290	1
3	Fitting*	CF669.096	1	50	Back-up washer	B1008.564	1
4	Back-up washer	B1014.565	1	51	O-ring	B1003.503	2
5	Plug	CF668.006	1	52	Release plunger sub assy.	CL209.040	1
6	Body	CJ37.950	1	53	Back-up washer	B1006.564	1
7	Filter	CB981.018	1	54	Gasket	P200.37	1
8	Screw	CF318.028	4	55	O-ring	B1118.903	1
9	Gasket	P200.37	4	56	Release guide	CM67.013	1
10	Ball seat	CH814.290	2	57	Spring	CB960.110	1
11	Ball	B1006.016	2	58	Spring washer	CH198.108	1
12	Spring (cone type)	CK53.110	1	59	Roller	CB923.281	1
13	O-ring	B1221.503	1	60	Dowel pin	CH200.061	1
14	Back-up washer	B1015.565	1	61	V-retainer coupling	CB219.044	1
15	Cylinder	CJ610.030	1	62	Base	CB108.005	1
16	"U" cup	CB918.041	1	63	Socket head cap screw	B1320.028	2
17	Bearing	CB624.108	1	64	Treadle	CB241.218	1
18	Internal retaining ring	CJ611.044	1	65	Ball seat	CB576.290	1
19	Spring	CH210.110	1	66	Ball guide	CH180.950	1
20	Washer	A8009.108	1	67	Spring	A8038.110	1
21	Plunger	CB180.040	1	68	Plug	A8005.007	1
22	Piston	CB109.051	1	69	Relief valve body	CB580.190	1
23	"U" cup	CB808.041	1	70	Socket set screw	L86.028	1
24	Pan head screw	CF157.028	1	71	Safety valve plug	B161.272	1
25	Washer seal	CB644.108	1	72	Ball guide	CH411.013	1
26	Copper washer	CB1004.503	1	73	Ball	B1007.016	1
27	Cylinder	CK970.030	1	74	Coupler body	CF692.950	1
28	O-ring	B1004.503	1	75	Coupler stem	CA978.110	1
29	O-ring	B1228.503	1	76	Spring	B1017.565	2
30	Piston	CB121.051	1	77	O-ring	B1017.903	2
31	O-ring	B1224.503	1	79	Reducer bushing	CF874.044	1
32	Poppet plunger	CH45.040	1	80	Retaining ring Hydraulic hose (see cover)	BP9906-31-11	1
33	Cover seal	CB919.041	1				
34	Cover	CK971.098	1				
35	O-ring	B1001.508	1				
36	Bushing	CH79.039	1				
37	Grommet	CH34.808	2				
38	Filter	CB256.018	1				
39	Retainer cover	CH49.098	1				
40	Button head cap screw	CB338.028	4				
41	O-ring	B1220.503	5				
42	Swivel coupler	CH8.034	1				
43	Retaining ring	CH50.044	1				
44	O-ring	B1001.503	2				
45	Piston	CB253.051	1				
46	Poppet guide	CB502.013	1				
47	Spring pin	B1040.057	2				

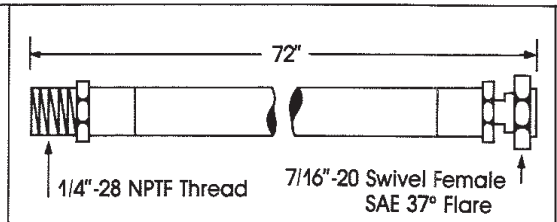

Rated Pressure 10,000 P.S.I.
Minimum Burst 20,000 P.S.I.

BP9906-31-11

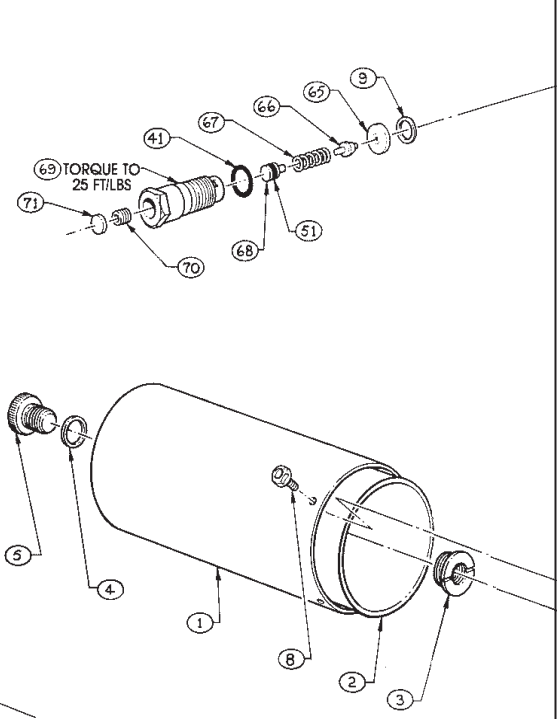

*CF180.900 assembly Complete

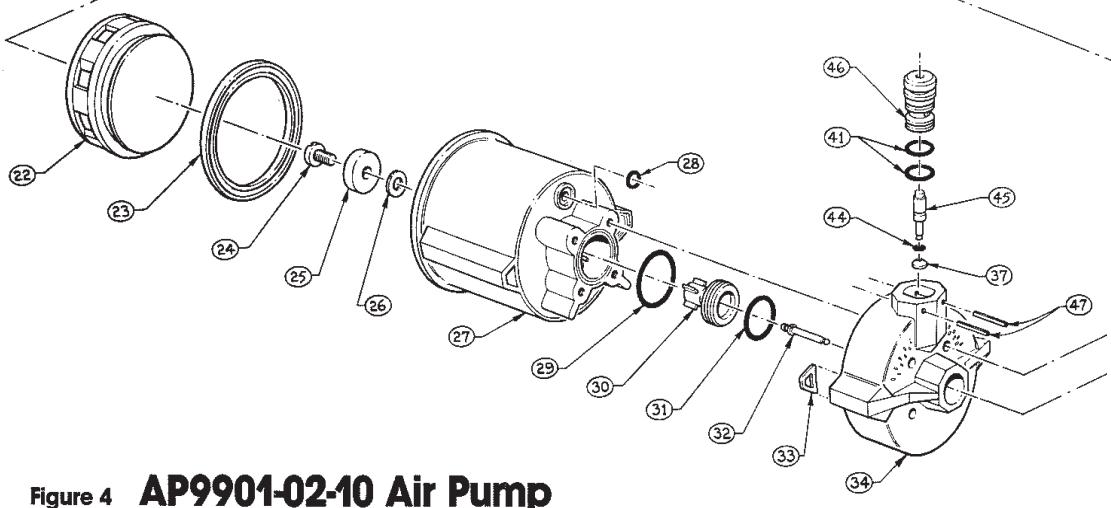

Figure 4 AP9901-02-10 Air Pump

ISO 9001:2000 CERTIFIED

www.cardinalcomponents.com • info@cardinalcomponents.com
W128 N8600 Old Orchard Rd., Menomonee Falls, WI 53051
Visa, Mastercard, Discover & AmerExp Accepted • Fax: 262.252.5033

CALL TODAY
800.236.3200

C900 Tool

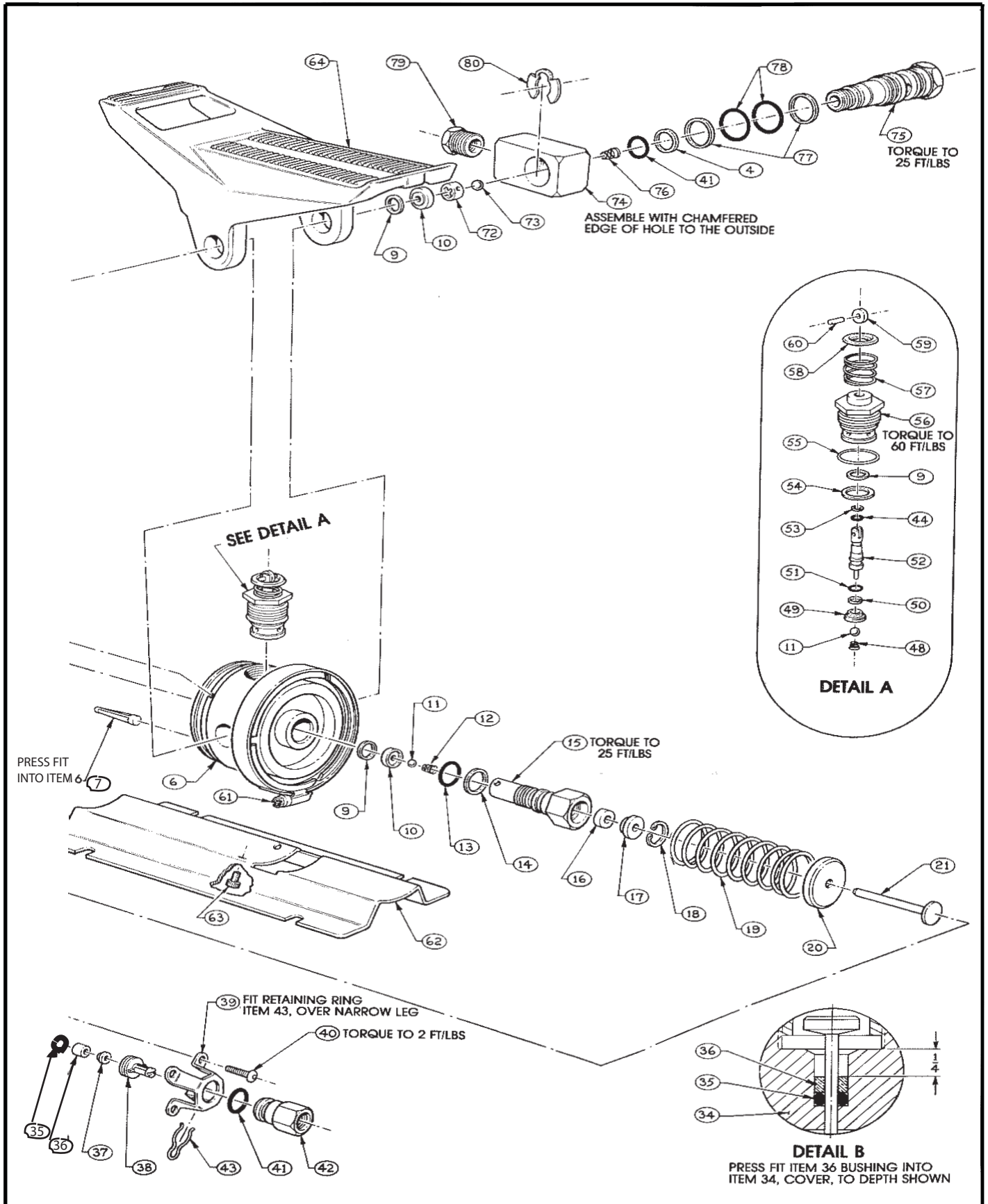

ISO 9001:2000 CERTIFIED

www.cardinalcomponents.com • info@cardinalcomponents.com
 W128 N8600 Old Orchard Rd., Menomonee Falls, WI 53051
 Visa, Mastercard, Discover & AmerExp Accepted • Fax: 262.252.5033

CALL TODAY
800.236.3200

C900 Tool

pressure and push remaining internal components out of release guide (56) revealing seals and "O" rings.

- b. Inspect all parts—replace if necessary. Reassemble in reverse order. After complete assembly is reinstalled in pump assembly, align roller (59) to be parallel with treadle (64). Valve should move smoothly when treadle is pressed forward or backward.

5. Hydraulic Cylinder Sub-Assembly

- a. Remove air motor assembly per instructions, paragraph 2 (page 6). Unthread cylinder (15) from body (6). Inspect all internal components. Reseat .219 dia. Steel ball (11) on ball seat (10) by lightly tapping steel ball with a light weight hammer on a soft drift.
- b. Remove truarc internal retaining ring (18) which will allow removal of bearing (17) and U-cup (16).
- c. After flushing entire system, replace parts in reverse order making sure tapered spring cone type (12) is installed with small end toward steel ball (11).

6. Coupler Sub-Assembly

Remove air hose assembly. Unthread sub-assembly (75) from tool. Retaining ring (80) can then be removed by pushing lightly upward thus allowing removal of coupler stem (75) from coupler body (74), This will allow access to internal components.

Inspect and replace all worn or damaged parts. Reseat .250 dia. ball (73) on removable ball seat (10). Install tapered spring (76) with small end toward ball (73). Flush entire system and after complete assembly of coupler stem (75) in coupler body (74) torque unit into body (6) to 25 ft. lbs.

7. Relief Valve Sub-Assembly

- a. The sub-assembly (69) includes a high pressure relief valve which is factory adjusted to prevent continual pumping at 80 psi air pressure. Exceeding 80 psi the pumping action will continue, causing a degree of difficulty determining when the fastener is completely upset. If pumping continues, the relief valve may require adjusting or tool may be low on hydraulic oil. **Always check oil first.**
- b. To adjust relief valve, remove safety valve plug (71) by punching hole with small screw driver. Using hole lift lead plug out. Adjust air pressure to pump at 80 psi, depress foot treadle applying maximum hydraulic pressure. At the same time thread socket set screw (71) in slightly until pumping just ceases. This is the correct adjustment setting to allow tool to override if air pressure exceeds that recommended.

WARNING

Do not over-tighten set screw. Relief valve is a safety overload, designed to relieve hydraulic pressure if excessive air pressure is inadvertently used.

Section IV Trouble Shooting

Air-Hydraulic Air Pump Trouble Shooting Chart

Condition	Possible Cause	Solution
Air motor fails to cycle or cycles slowly.	1. Air pressure too low. 2. Air orifice restricted. 3. Air piston jammed. 4. Hydraulic piston jammed. 5. Gummy piston #30.	Check air supply for recommended pressure. Remove air line and clean area. Disassemble motor—clean or replace piston if needed. Disassemble, clean and replace worn or damaged parts. Clean and lubricate.
Air motor cycles but fails to pump.	1. Air in reservoir or in system. 2. Dirty valves (73) and (66).	Fill with oil and bleed out all air. Clean and reseat, flush entire system.
Pumps but fails to hold pressure.	1. Leak in hydraulic system. 2. Release valve not closing. 3. Dirty valve (73) and (66).	Locate and repair. Return of proper adjustment. Clean, reseat, flush entire system.
Oil leaking.	1. Reservoir fill plug (5). 2. Reservoir damaged. 3. Line fittings.	Replace washer #4 and tighten. Replace complete assembly (1, 2 and 3). Clean and tighten—replace if damaged.

ISO 9001:2000 CERTIFIED

CALL TODAY
800.236.3200